

ROUND -TAKEOFF POWER OPEN/POWER CLOSE*

POWER DAMPERS POWER OPEN /POWER CLOSE DAMPERS USE THREE WIRES TO POWER THE DAMPER OPEN OR POWER IT CLOSED. THE ZONE PANEL IS RESPONSIBLE FOR SUPPLYING A 24VAC SIGNAL TO EITHER THE PO (POWER OPEN) OR PC (POWER CLOSED) TERMINAL OF THESE DAMPERS. PRIMARY ADVANTAGES OF POWER OPEN/POWER CLOSE DAMPERS INCLUDE LOWER POWER CONSUMPTION, QUIET OPERATION AND GREATER RELIABILITY.

- **RELIABLE ACTUATOR WITH HIGH TORQUE & LOW POWER CONSUMPTION**
- **HEAVY DUTY GALVANIZED DAMPER WITH 1 CRIMPED & 2 BEADED ENDS**
- **PRECISION CONSTRUCTION & QUALITY PARTS FOR LONG-LIFE & QUIET OPERATION**
- **360° FULL-DIAMETER POLY GASKET FOR LOWEST LEAKAGE SEAL**
- **SET MINIMUM OR MAXIMUM OPEN & CLOSE**
- **ALL METAL SHAFT WITH NYLON BUSHINGS & TENSION CLIPS TO ENSURE FREE MOVEMENT**

© 2021 ECOJAY LLC
888-523-3265
ECOJAY.COM

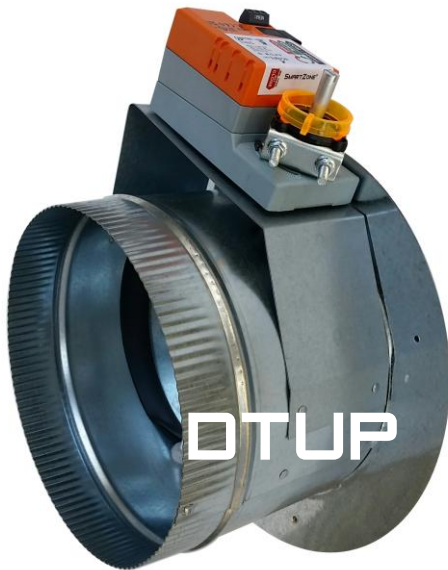

PART

DTUP06
DTUP07
DTUP08
DTUP09
DTUP10
DTUP12
DTUP14
DTUP16
DTUP18

D
6"
7"
8"
9"
10"
12"
14"
16"
18"

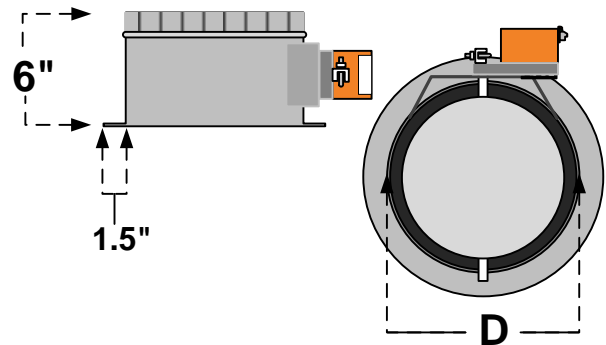

SPECIFICATIONS

TUBE (CAN):	22 - 24 GA. GALVANIZED STEEL
BLADE:	GALVANIZED STEEL WITH SANDWICHED URETHANE (RUBBERIZED) GASKET
SHAFT:	5/16" ROUND ALUMINUM
BUSHINGS:	HARDENED NYLON
WIRING:	18 OR 20 AWG (OPEN -PO, CLOSE- PC, COM -24VAC COMMON)
MOUNTING:	ANY ORIENTATION, FLEX DUCT, HARD DUCT, SPIRAL DUCT, STARTING COLLAR, ETC
MOTOR:	PART # APDM-B POWER OPEN/POWER CLOSE (3-WIRE) VOLTAGE: 24VAC / 60HZ POWER: 2.5VA (1.5W) TORQUE: 18IN-LB (2NM) TRAVEL TIME: 35 SEC +/- 0.25 TRAVEL ANGLE: 90 DEG (FULL OPEN/CLOSE)



WIRING

USE 18-AWG SOLID WIRE TO CONNECT "COM", "OPEN" & "CLOSE" TERMINALS TO SMARTZONE

CLUTCH

USE THIS BUTTON TO MANUALLY ROTATE THE SHAFT/BLADE

SHAFT CLAMP

TO REMOVE MOTOR, LOOSEN TWO NUTS ON THE V-BOLT

MIN / MAX SETTING

MOVE SCREWS TO SET A MINIMUM OR MAXIMUM OPEN OR CLOSE OF THE DAMPER

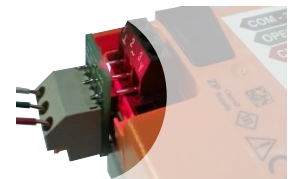

LED & SCREWLESS TERMINAL
ADD-ON AVAILABLE
GREEN = OPEN
RED = CLOSED

